

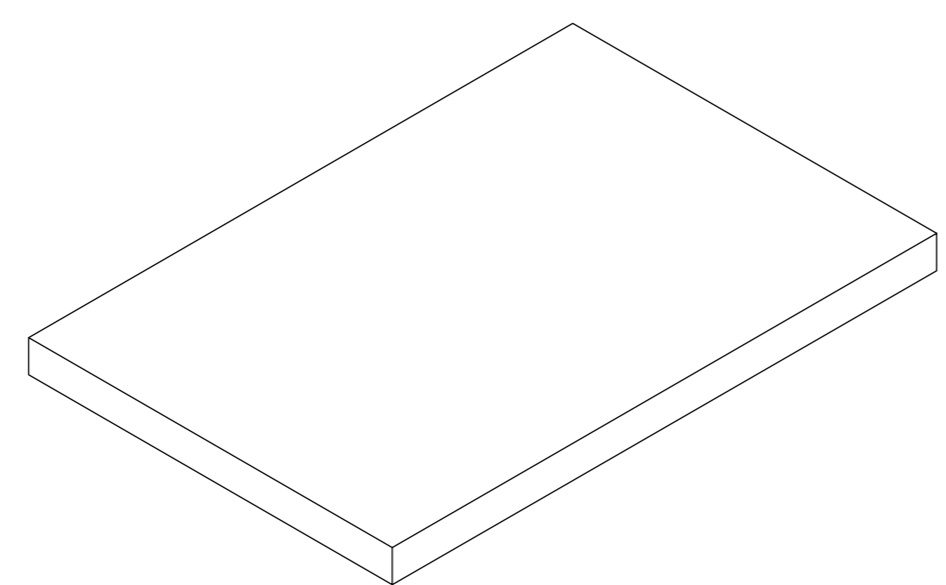

BYD_MIC/K-30 35mm Packaging

Step I



4、Top Cover: ABF,5-layer Corrugated Cardboard

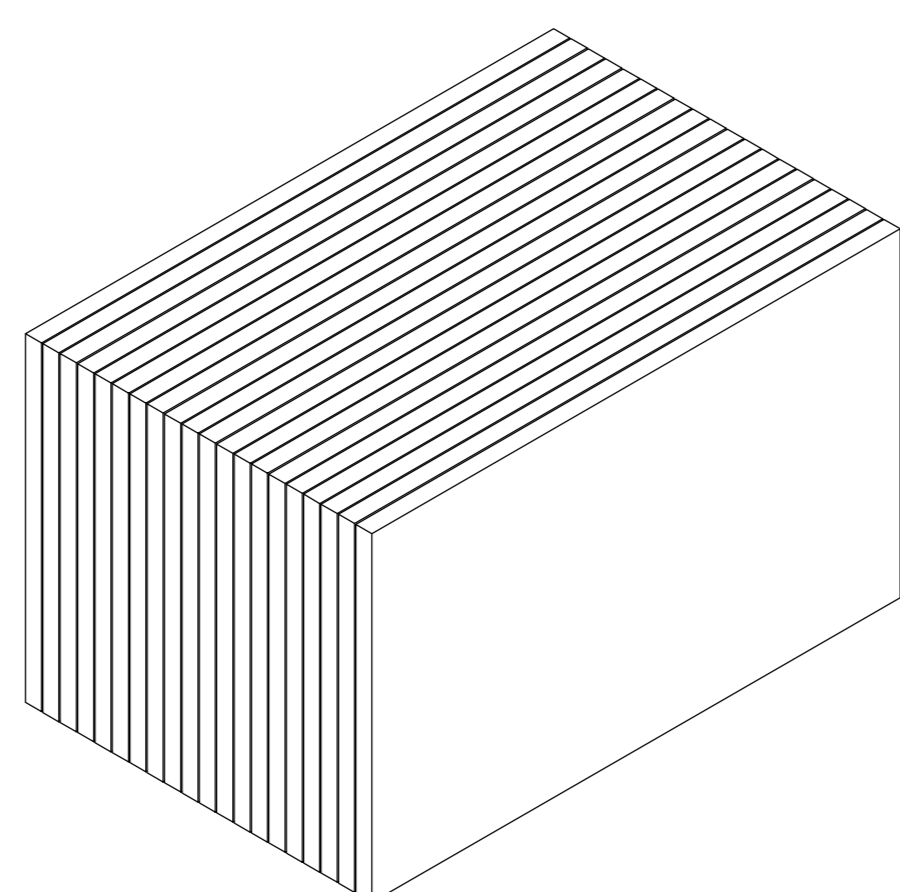
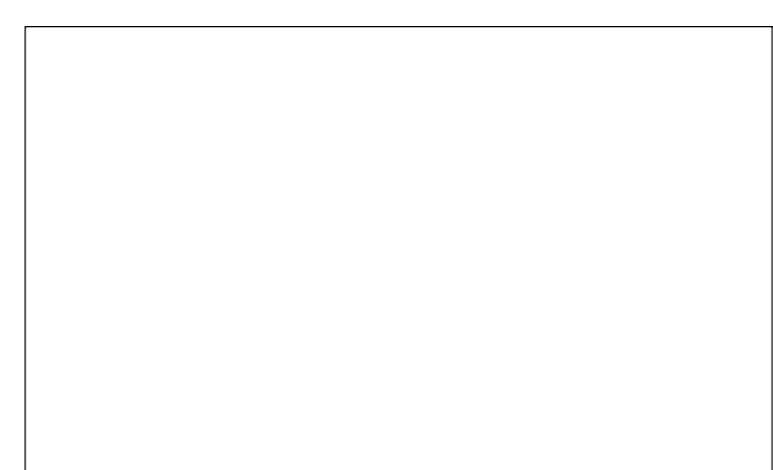

3、30PCS Modules: each corner of the modules are protected by 3-layer corrugated cardboard

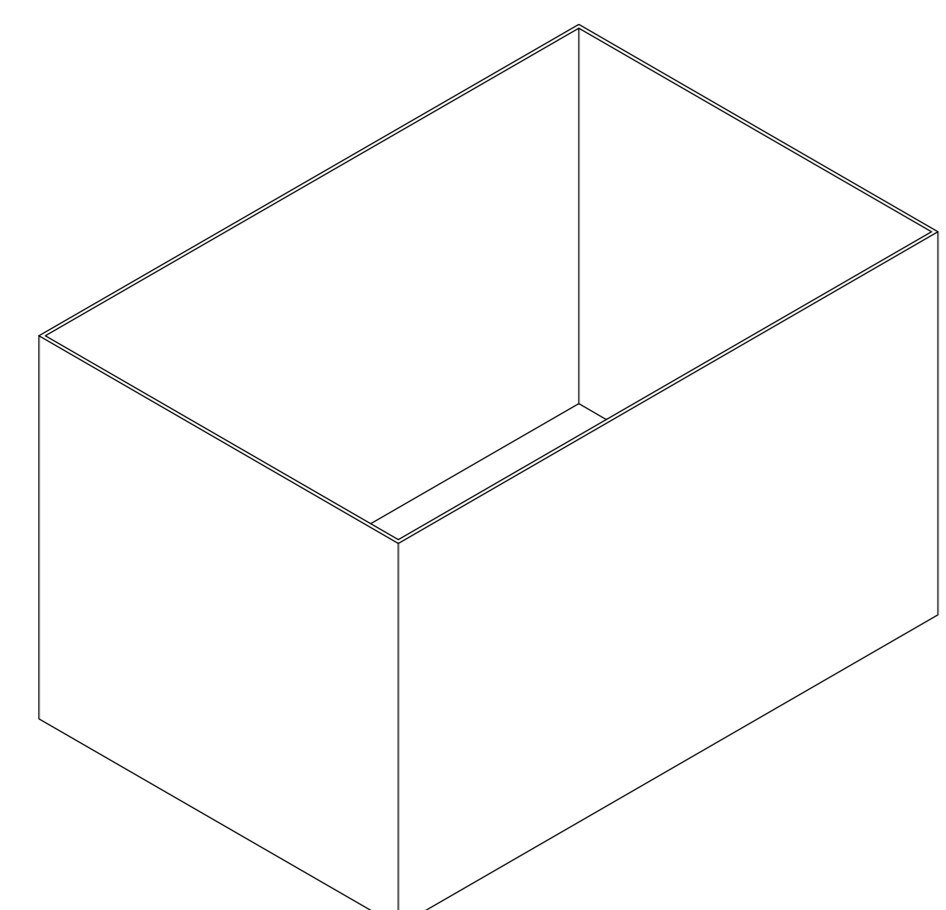

2、cartoon: ABCF-7-layer Corrugated Cardboard;

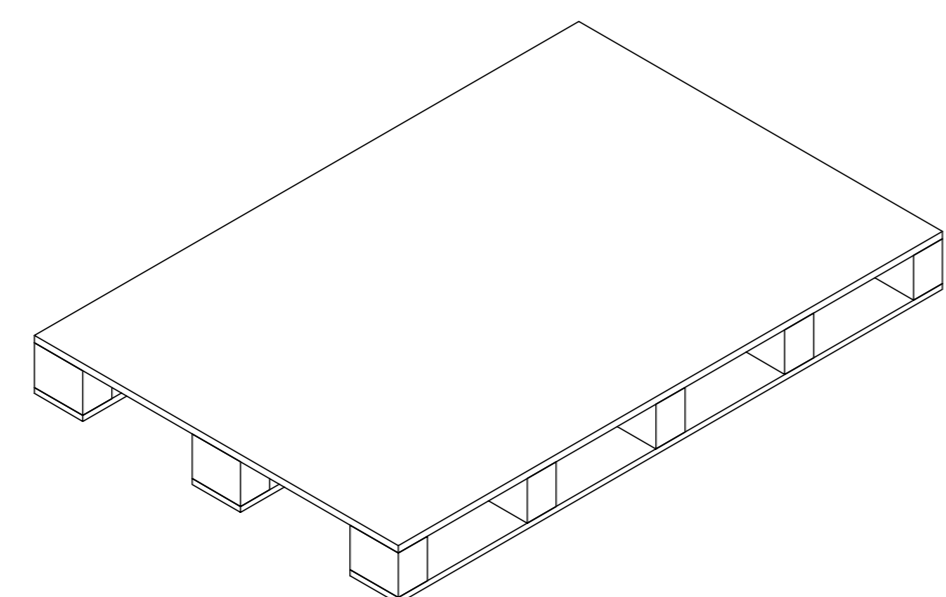

1、Pallet: Plywood;

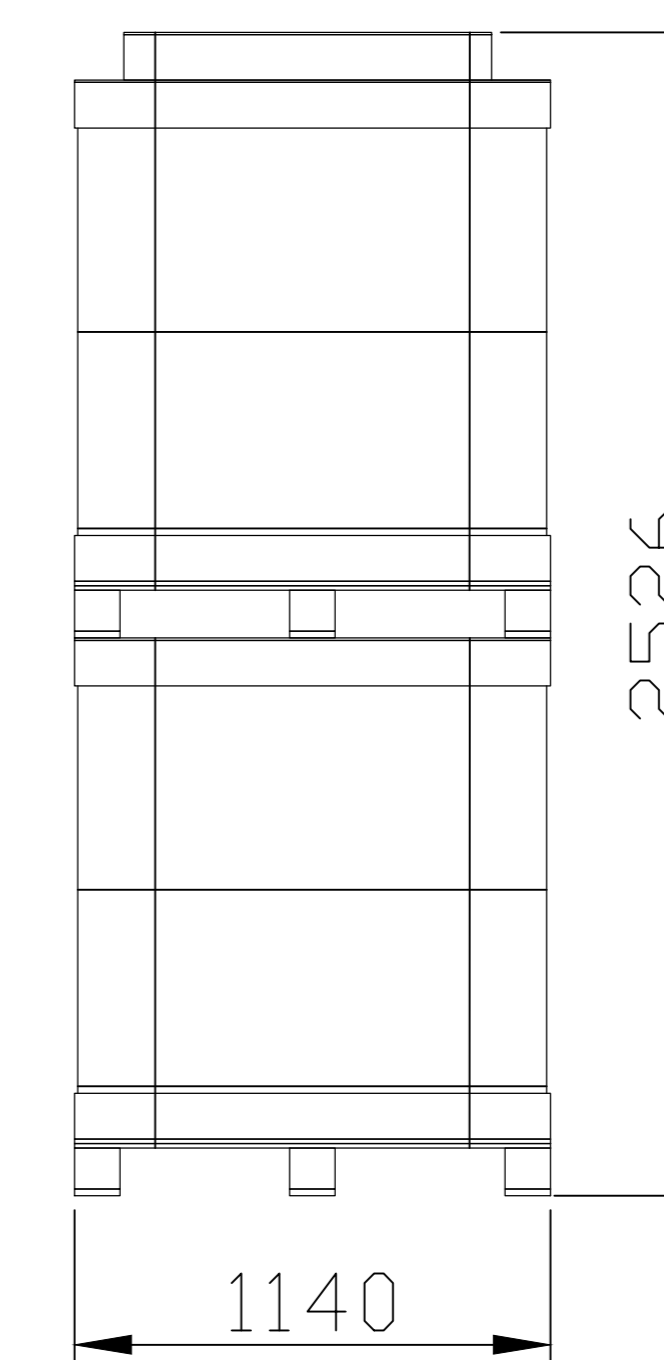
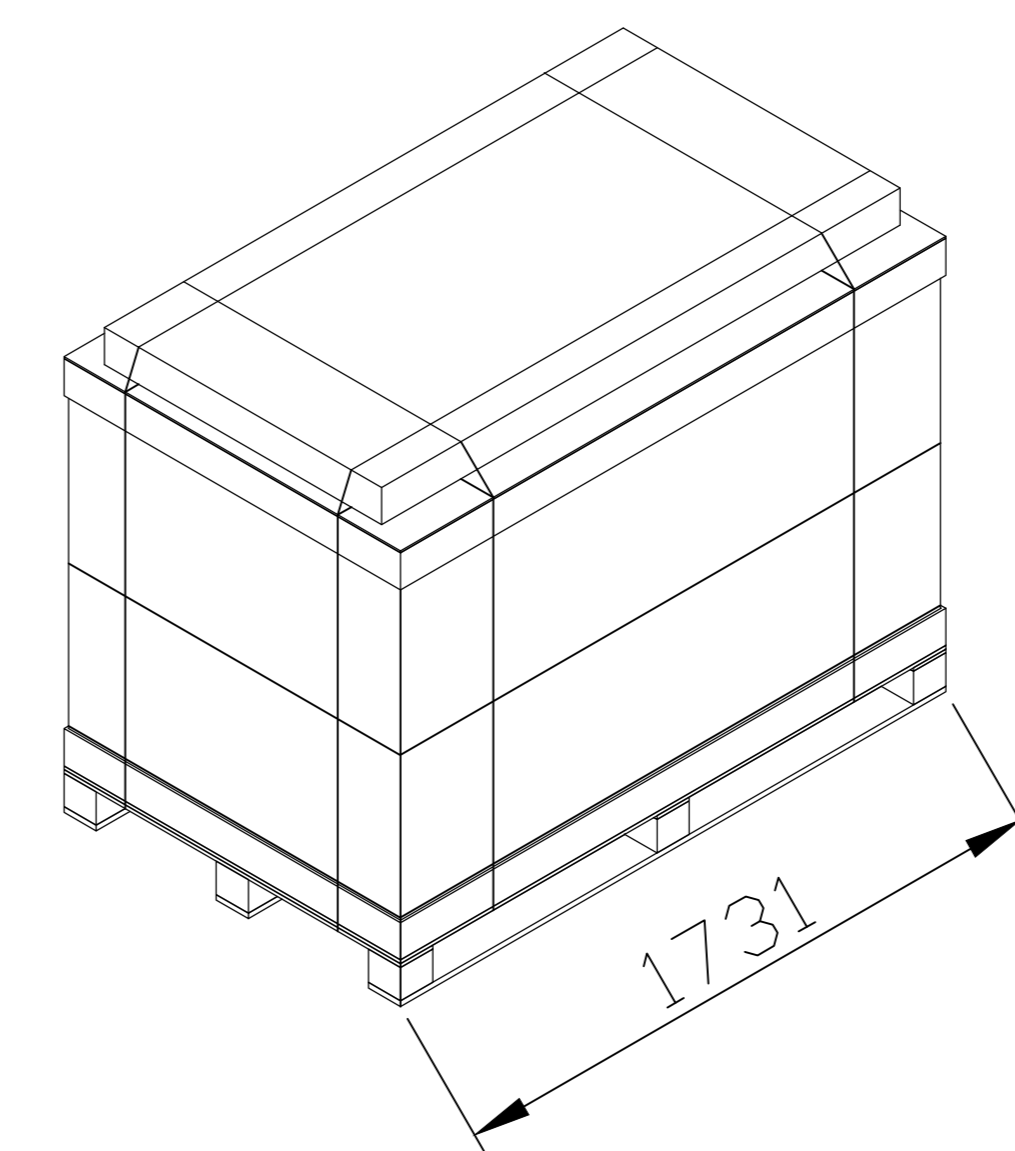
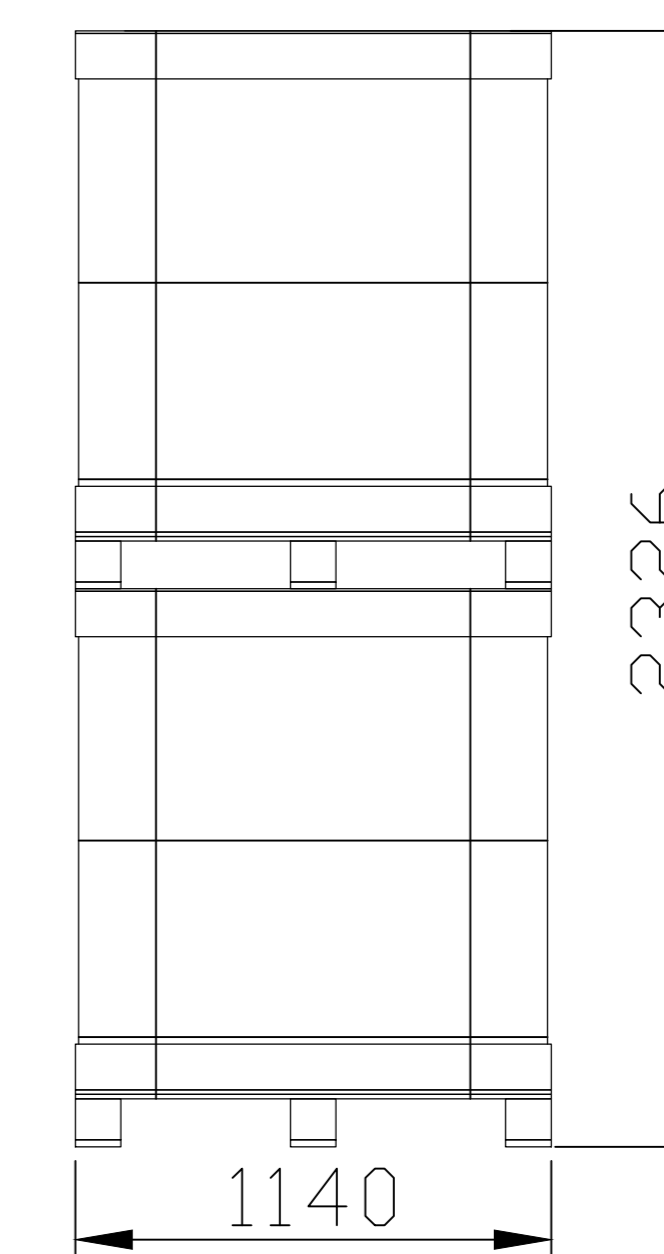
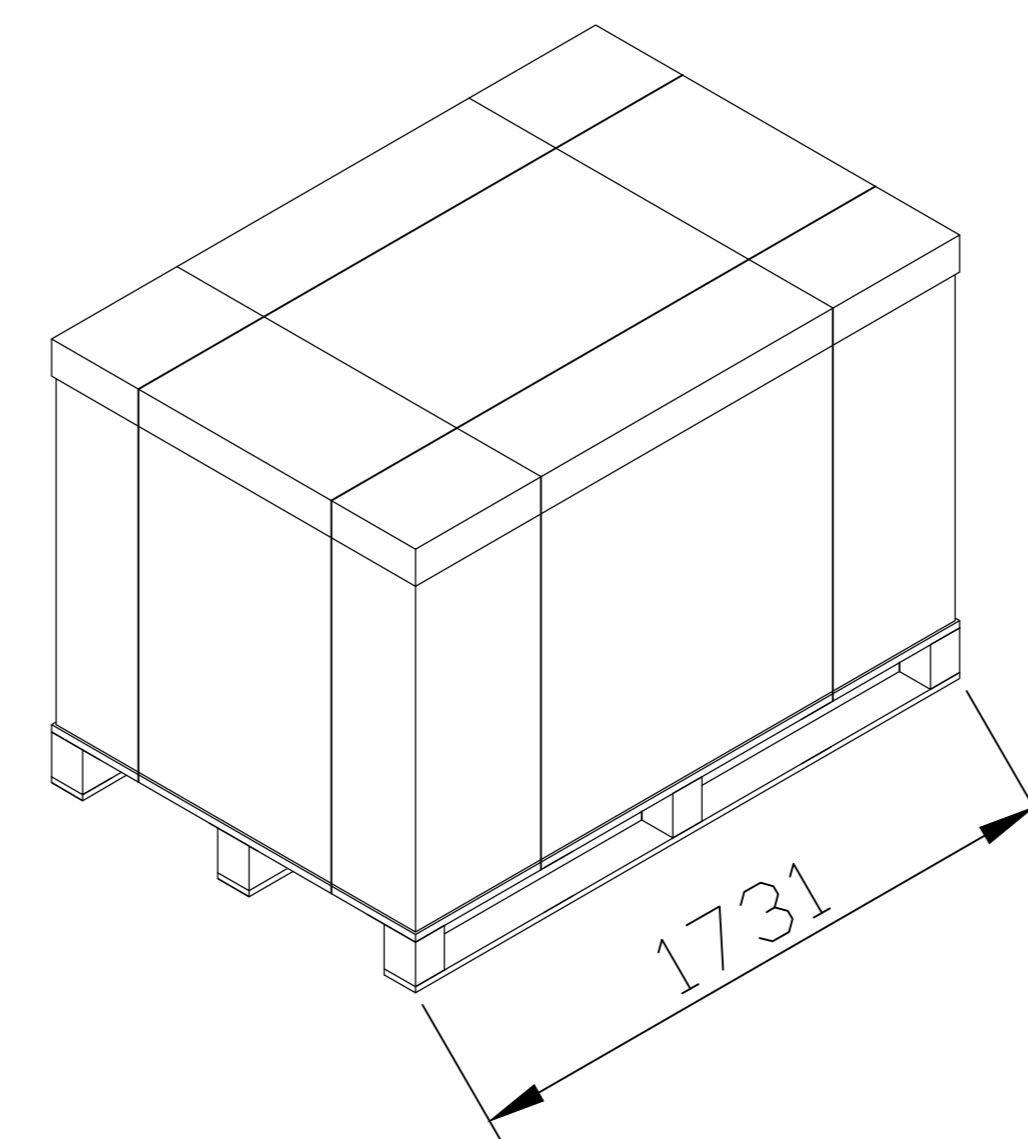

40'HQ:
11900*2330*2580mm
30pcs/pallets+5pcs/pallets
26pallets/container
845pcs/container

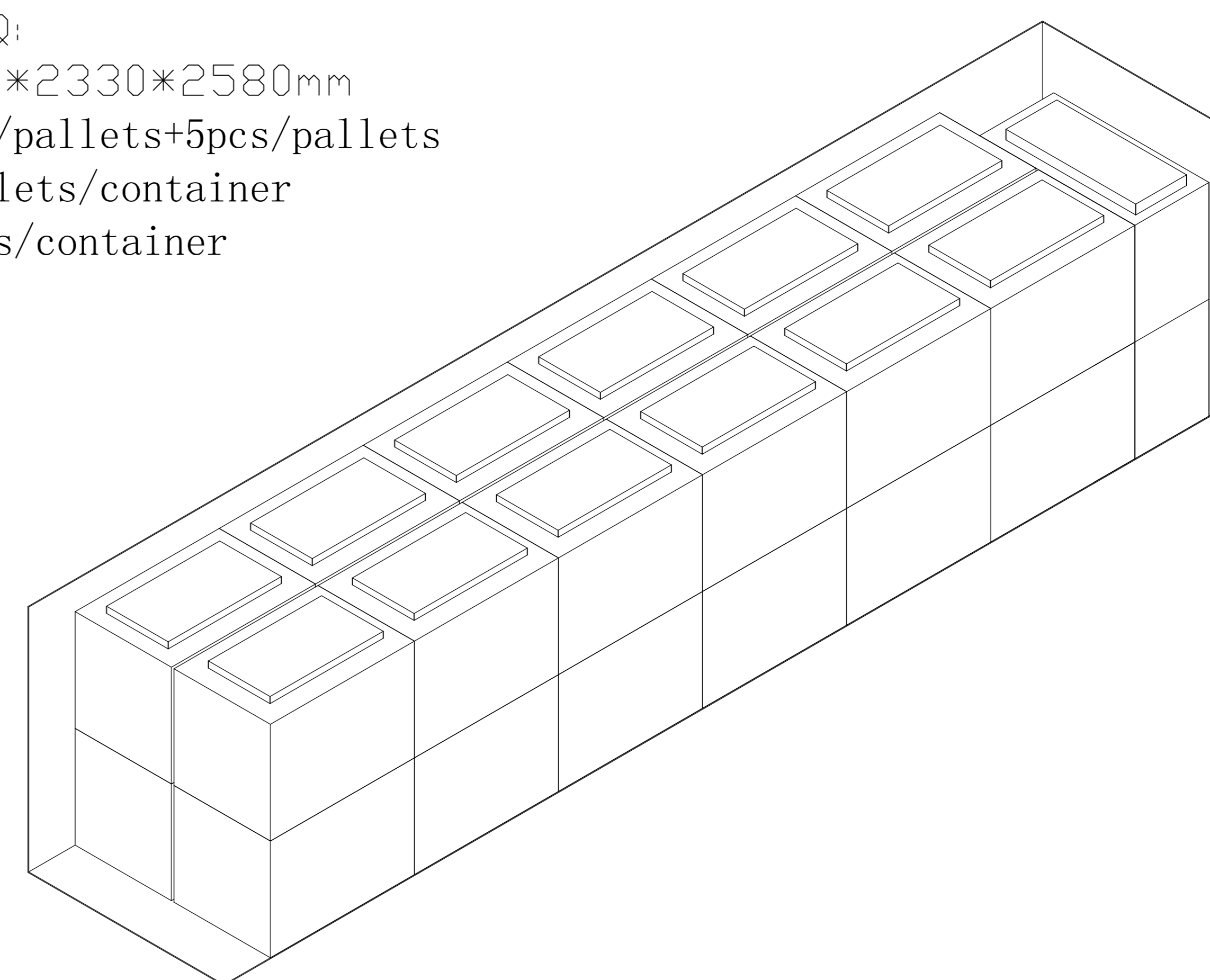

Step II

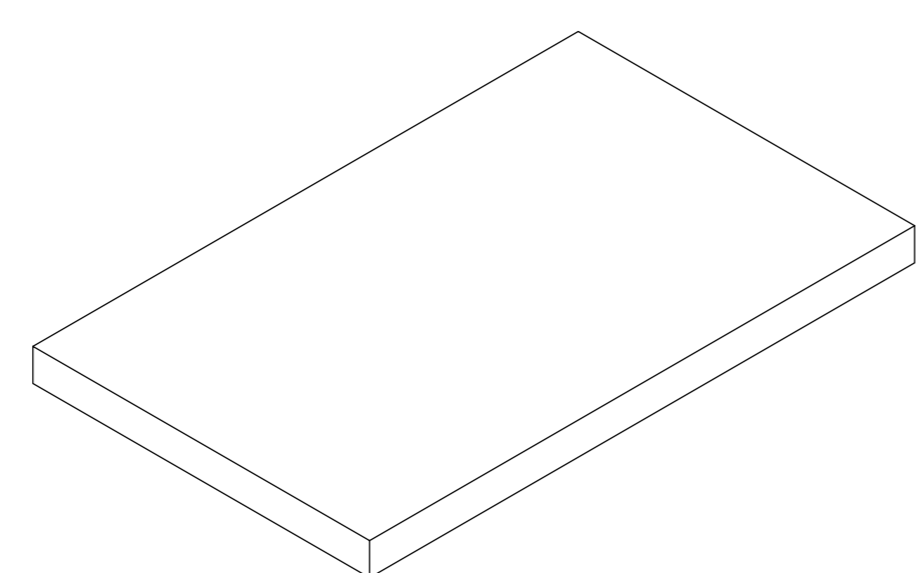
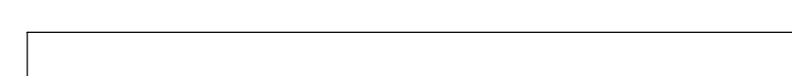

3、Top Cover: ABF,5-layer Corrugated Cardboard

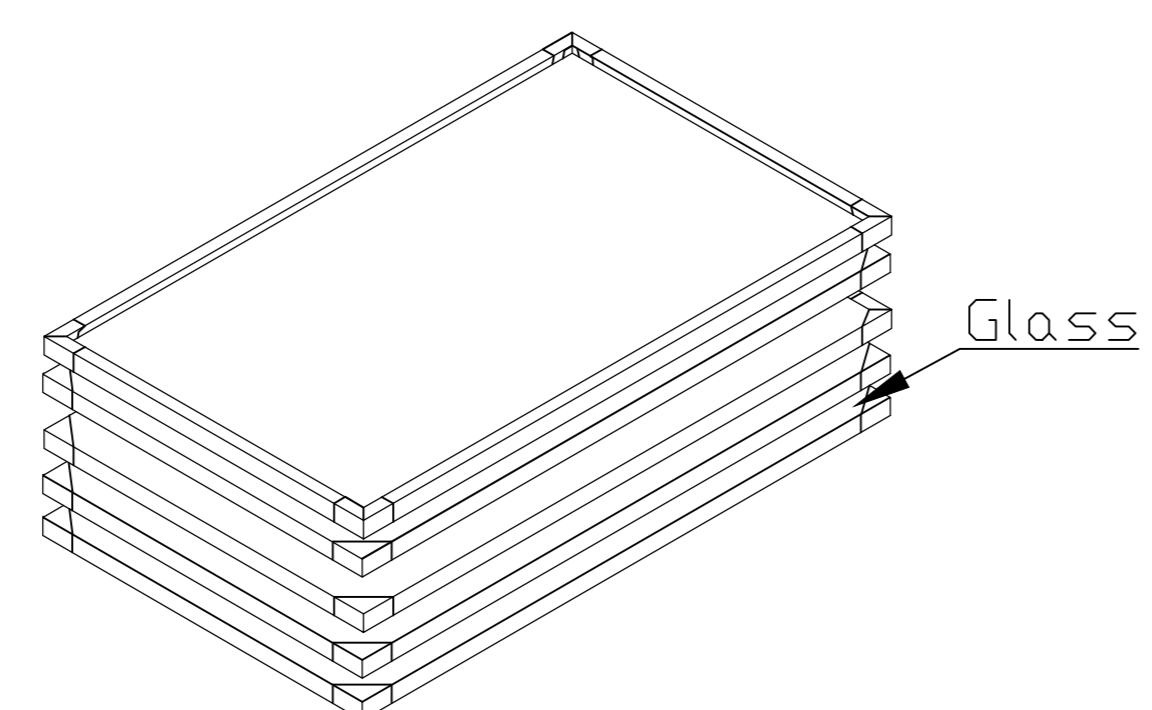
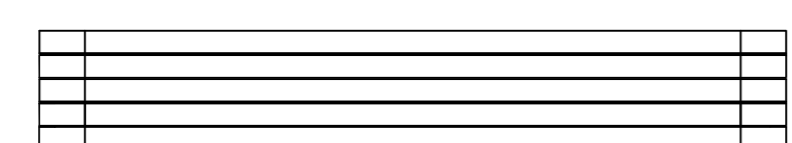

2、5PCS Modules: Each has 4 paper corner

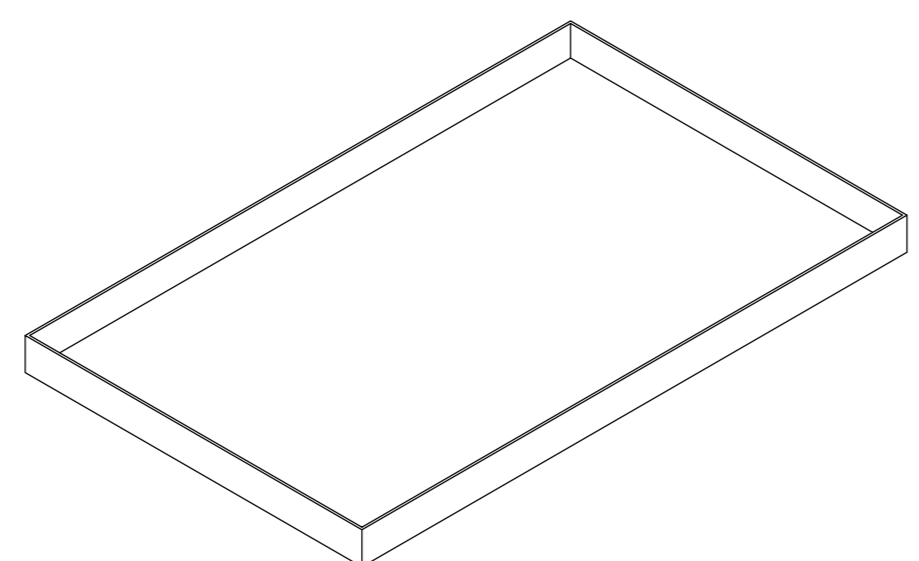

1、Bottom: ABF-5-layer Corrugated Cardboard;

Notes:
1、Pallet Dimension:1731*1140*1163mm
2、26 pallets/40'HQ, 26*30+5*13=845PCS/container
3、N. W. 558Kg/pallets+93Kg/pallets
G. W. 607Kg/pallets+97Kg/pallets
N. W. 15717Kg/container
G. W. 17043Kg/container