

## REFUstore 50K...100K

The next generation of bidirectional high power battery inverters



- Drastic reduction in BOS costs
- Maximum power density
- Easy serviceability
- Suitable for 2nd Life Battery Application

The REFUstore battery inverter is based on the new inverter platform from REFU. This inverter is specifically designed for all high voltage batteries. With a rated power of 88 kW at 400V, it is perfectly suited for commercial behind-the-meter applications such as self-consumption optimization or peak-shaving.

**Future Proof:** The AC-coupled REFUstore can be easily integrated with existing PV systems. The highly modular solution allows it to be used in systems from 50 kW up to MWs in size to meet the demands of both energy and power applications.

**Maximum Performance:** The REFUstore is highly efficient over a wide range of operation maximizing return on investment. With fast response times, the inverter achieves high control performance, making it suitable for time-critical applications.

**Design Flexibility:** The REFUstore allows different communication protocols like Modbus RTU/TCP and Sunspec/MESA. The higher flexibility in system design reduces BOS costs drastically.

**2nd Life Application:** With a min. DC voltage of 280V, the REFUstore 50K can be used in 2nd life battery applications with ease to support the grid for applications such as frequency regulation, optimizing self-consumption, peak shaving etc.



# TECHNICAL DATA – POWERUNIT

Art. No.	REFUstore 88K/100K				REFUstore 50K	
	420P088.020				420P050.020	
Art. No. (DC-precharge integrated)	421P100.010				421P050.010	
Operation Mode	100 kVA @ 480 VAC	88 kVA @ 400 VAC	83 kVA @ 380 VAC	50kVA @ 400 VAC	50kVA @ 380 VAC	2nd Life application

## DC DATA

Max. voltage DC (V)	1,000					
Nominal voltage DC (V)	750	620	600	620	600	U <sub>dc</sub> + 50
DC voltage range at nominal power (V)	700... 900	585... 900	555... 900	585... 900	555... 900	1.46 × U <sub>ac</sub>
DC start-up open circuit voltage, U <sub>dc</sub> (V)	700	585	555	585	555	1.46 × U <sub>ac</sub>
Max. operational current DC (A)	153	153	153	153	87	153
DC connection PowerUnit - ConnectionBox	1 Plus, 1 Minus: Connector with Button Activated Coupling					

## AC DATA

Apparent power (kVA)	100.0	88.0	83.3	50.0	50.0	0.222 × U <sub>ac</sub>
Rated voltage AC 3-Phase, U <sub>ac</sub> (V)	480	400	380	400	380	180 ... 480
Voltage range AC (V)	180 ... 528					
AC grid connection / Grid types	3 Phases, PE / TT, TN-C, TN-S					
Nominal power factor / Range	1 / 0.3i ... 0.3c					
Rated frequency / Frequency Range (Hz)	50, 60 / 45 ... 65					
Max. AC current, I <sub>max</sub> (A)	128					
Max. AC short circuit current (A rms)	64 (3 period average)					
Inrush current (peak / duration)	25 A / 0.5 ms					
Max. THD (%)	< 3					
Max. efficiency (%)	98.4	98.4	98.3	98.4	98.4	96.8
Maximum admissible external AC fuse	160 A, gG, U <sub>n</sub> = 500 V					
Maximum admissible external DC fuse	200 A, gR, U <sub>n</sub> = 1000 V					
Peak current (I <sub>p</sub> ) / Initial short circuit current (I <sub>k</sub> ) acc. IEC 60690-0 (A)	128 / 325					
AC connection PowerUnit - ConnectionBox	Connector with Button Activated Coupling					

## AMBIENT CONDITIONS

Cooling	Smart active cooling					
Max. temp. for nominal power (°C)	45					
Ambient temperature (°C)	- 25 ... + 60					
Rel. Air humidity (%)	0 ... 100					
Max. elevation (m above sea level)	3,000					
Noise level (dBA)	< 70					
Environment classification (IEC 60721-3-4)	4K4H					
Type of protection	IP65					
Installation type	Indoor / outdoor, Vertical / flat / pole mounting					

## SAFETY AND PROTECTION FUNCTIONS

Safety and protection devices	Refer to ConnectionBox					
Grid monitoring (acc. DIN V VDE V 0126-1-1)	Voltage, Frequency, Passive and Active Anti-Islanding, DC injection					
Grid separation	Gate Block / redundant Grid Relays					
Residual current monitoring (RCD)	Type 2					
Compatibility external RCD	Type A / Type B					
Protection class (IEC 62109)	1					
Overvoltage category (IEC 60664-1)	DC: II / AC: III					
DC-precharge	420Pxxx.020: no (required externally) 421Pxxx.010: (integrated)					

# TECHNICAL DATA – POWERUNIT

	REFUstore 88K/100K			REFUstore 50K		
Art. No.	420P088.020			420P050.020		
Art. No. (DC-precharge integrated)	421P100.010			421P050.010		
Operation Mode	100 kVA @ 480 VAC	88 kVA @ 400 VAC	83 kVA @ 380 VAC	50kVA @ 400 VAC	50kVA @ 380 VAC	2nd Life application

## GENERAL DATA

Topology	Transformerless
DC pole grounding	not allowed
Status display / Keys	4 LED's (DC status, AC status, Fault, Bluetooth®) / 2 Keys (Connect, Clear)
Interfaces	2 × Ethernet Daisy-Chain / 2 × RS485, Bluetooth® BLE, 1 × Remote Off Signal
Communication Protocols	Sunspec (Modbus TCP, Modbus RTU), USS (Ethernet, RS485)
Dimensions W × H × D (mm)	673 × 626 × 321
Weight (kg)	69

## CERTIFICATES

EU Directive	2014/30/EU, 2014/35/EU
Product	IEC 62109-1, IEC 62109-2, IEC 62116, IEC 61727, IEC 62477-1, IEC 61439, ETSI EN 300 328 V.2.1.1
EMC	IEC 61000-6-2, IEC 61000-6-4
Environment	IEC 60068-2-1, -2-2, -2-30, -2-78, -2-14, -2-6, -2-27, -3-2, -2-75, IEC 60529, IEC 60034-9
Grid Codes	DIN VDE V 0126-1-1, VDE AR-N 4105:2011-08, BDEW Prototype Declaration, TOR D4, Önorm E 8001-4-712, UTE C15-712-1, EN 50438, VDE AR-N 4105:2018, VDE AR-N 4110:2018, EN 50438 (BG, CY, HU, PL, RO, TR)

All certificates are available at [www.refu.com](http://www.refu.com)

## EFFICIENCY

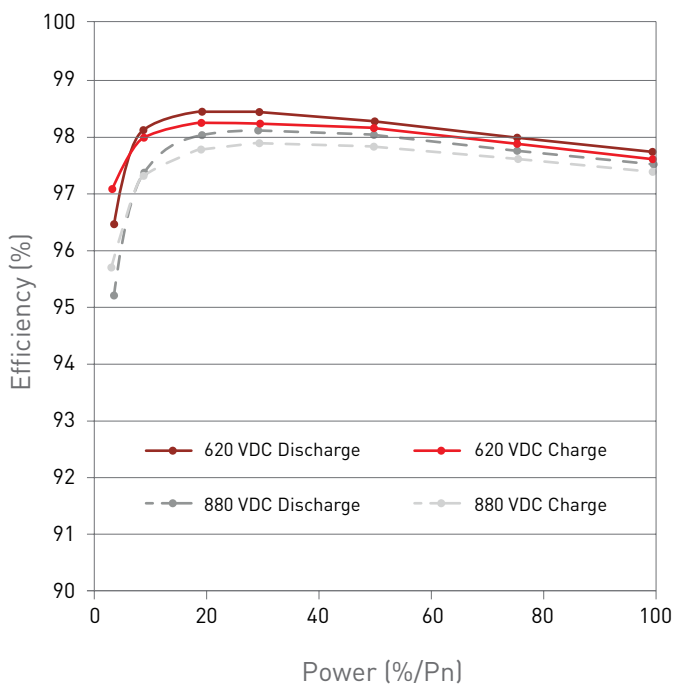

## POWER / TEMPERATURE

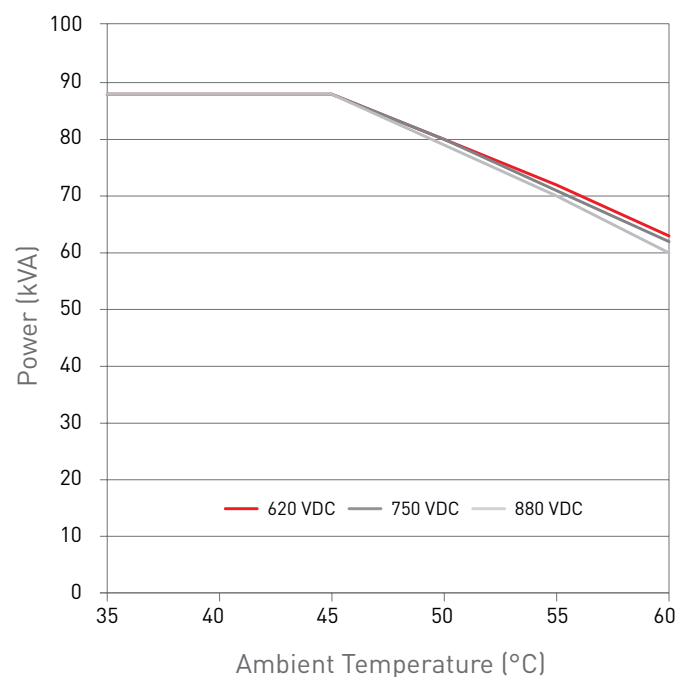

Art. No.

**CBBS (1000V-BR)**  
**940P300.0000**

**GENERAL DATA**

DC Switch	no
DC Connection (+ / -)	Ring terminal block (50 ... 240 mm <sup>2</sup> )
AC Connection	L1, L2, L3: M10 / PE: M8 Ring terminal block (50 ... 150 mm <sup>2</sup> )
Type of protection (IEC 60529)	IP54
Dimensions ConnectionBox W × H × D (mm)	760 × 692 × 166
Weight (kg)	25

**POWERUNIT**

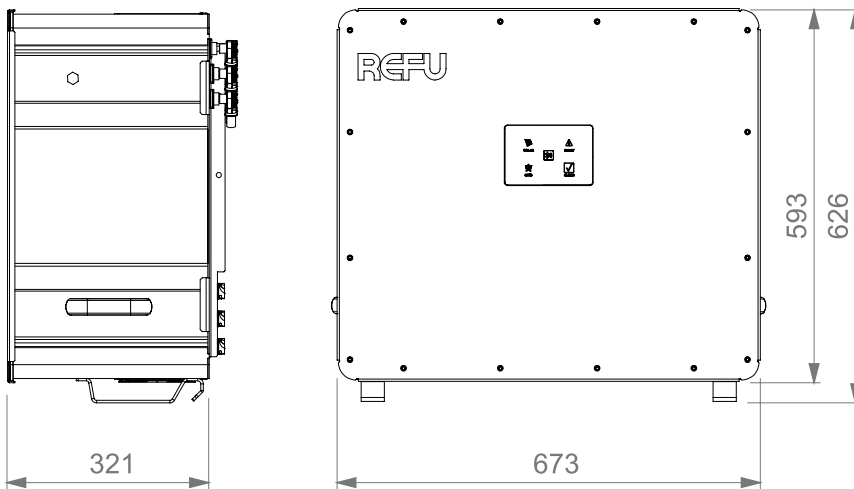

**CONNECTIONBOX**

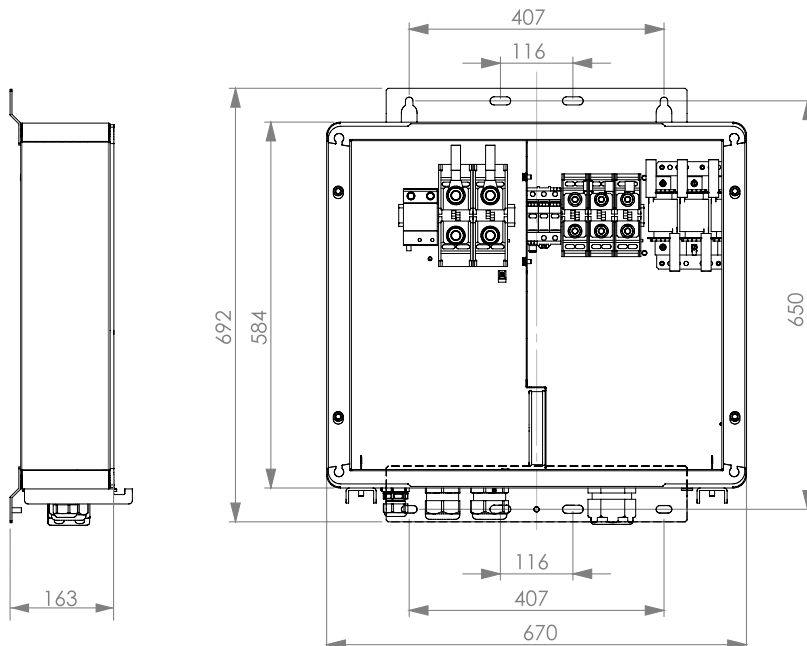

OVERALL SYSTEM

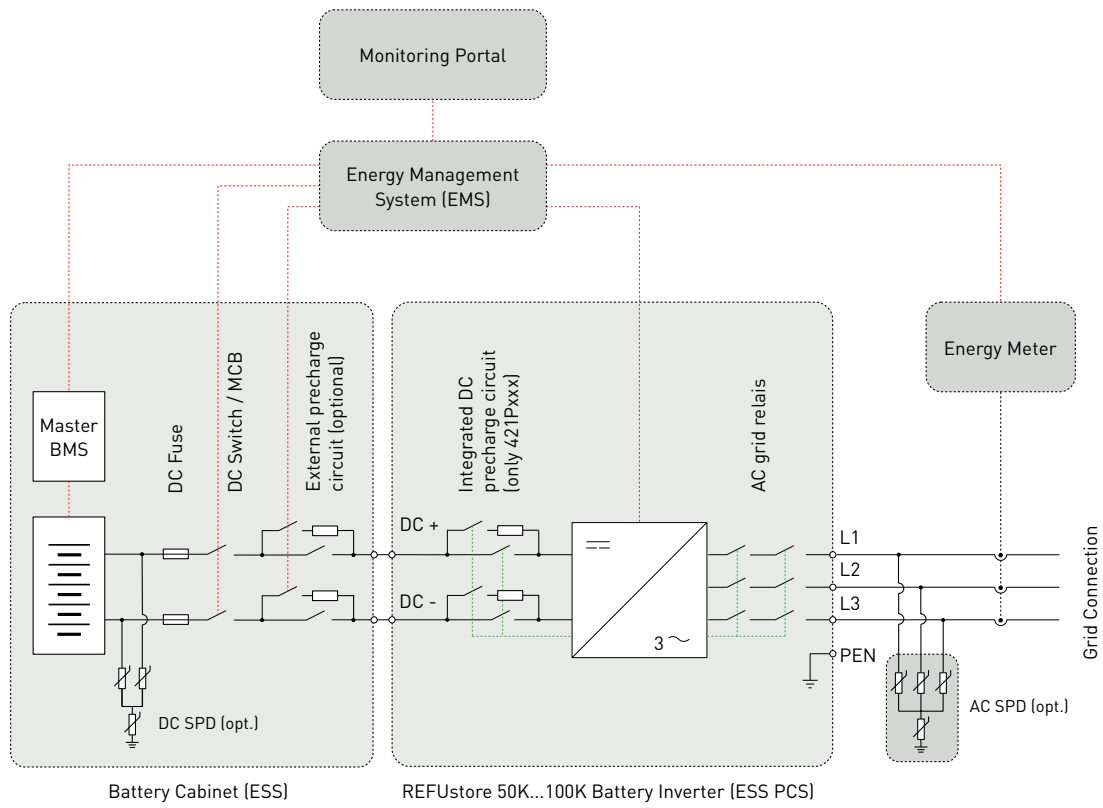

POWERUNIT

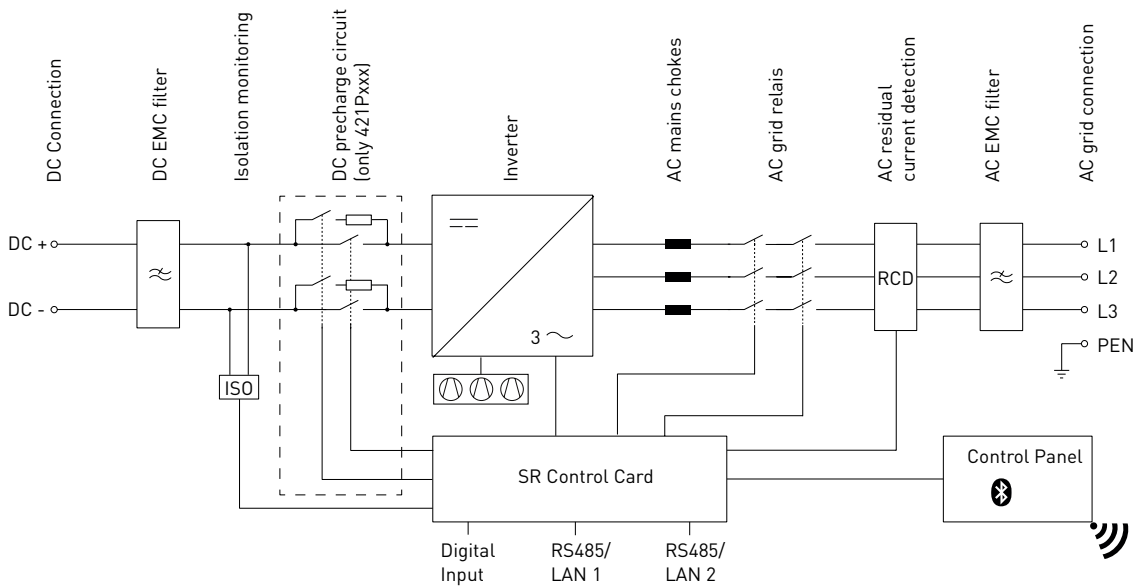

## INSTALLATION MADE EASY

The ConnectionBox and PowerUnit can be delivered individually in separate shipments. The ConnectionBox can be installed during cable work and the PowerUnit just before commissioning, thereby optimizing investment and project cash flow.

This two-piece design also offers easiest serviceability – the PowerUnit can be quickly detached from the ConnectionBox for trouble shooting and measurements – without disconnecting the power cables on the DC or AC sides.

1



Install and wire the ConnectionBox.

2



Hang in PowerUnit before commissioning.

3



Ready.